

The Security Hardening Guide for the NPort 6000 Series

Moxa Technical Support Team
support@moxa.com

Contents

1. Introduction.....	2
2. General System Information.....	3
2.1. Basic Information About the Device.....	3
2.2. Deployment of the Device.....	3
3. Configuration and Hardening Information.....	4
3.1. TCP/UDP Ports and Recommended Services.....	5
3.2. HTTPS and SSL Certificates.....	10
3.3. Account Management.....	13
3.4. Accessible IP List.....	16
3.5. Logging and Auditing.....	17
4. Patching/Upgrades.....	18
4.1. Patch Management.....	18
4.2. Firmware Upgrades.....	18
5. Security Information and Vulnerability Feedback.....	19

Copyright © 2021 Moxa Inc.

Released on March 26, 2021

About Moxa

Moxa is a leading provider of edge connectivity, industrial computing, and network infrastructure solutions for enabling connectivity for the Industrial Internet of Things (IIoT). With over 30 years of industry experience, Moxa has connected more than 57 million devices worldwide and has a distribution and service network that reaches customers in more than 70 countries. Moxa delivers lasting business value by empowering industries with reliable networks and sincere service. Information about Moxa's solutions is available at www.moxa.com.

How to Contact Moxa

Tel: +886-2-8919-1230

MOXA®

1. Introduction

This document provides guidelines on how to configure and secure the NPort 6000 Series. The recommended steps in this document should be considered as best practices for security in most applications. It is highly recommended that you review and test the configurations thoroughly before implementing them in your production system in order to ensure that your application is not negatively impacted.

2. General System Information Basic Information About the Device

Model	Function	Operating System	Firmware Version
NPort 6000 Series	Device server	Moxa Operating System	Version 1.20

The NPort 6000 Series is a device server specifically designed to allow industrial devices to be directly accessible from a network. Thus, legacy devices can be transformed into Ethernet devices, which then can be monitored and controlled from any network location or even the Internet. Different configurations and features are available for specific applications, such as protocol conversion, Real COM drivers, and TCP operation modes, to name a few. The series uses TLS protocols to transmit encrypted serial data over Ethernet.

Moxa Operating System (MOS) is an embedded proprietary operating system that is only used in Moxa edge devices. Because the MOS operating system is not freely available, the chances of malware attacks are significantly reduced.

2.2. Deployment of the Device

You should deploy the NPort 6000 Series behind a secure firewall network that has sufficient security features in place to ensure that networks are safe from internal and external threats.

Make sure that the physical protection of the NPort devices and/or the system fulfill meet the security needs of your application. Depending on the environment and the threat situation, the form of protection can vary significantly.

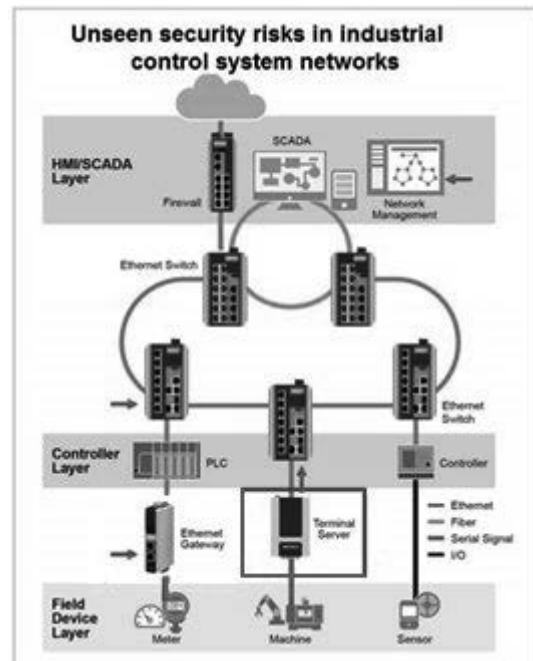

3. Configuration and Hardening Information

For security reasons, account and password protection is enabled by default, so you must provide the correct account and password to unlock the device before entering the web console of the gateway.

The default account and password are **admin** and **moxa** (both in lowercase letters), respectively. Once you are successfully logged in, a pop-up notification will appear to remind you to change the password in order to ensure a higher level of security.

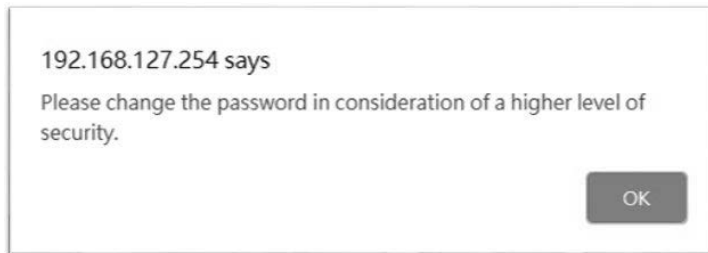

From firmware version 1.20, there is no default username or password. You should immediately create a username and password after logging in for the first time to enhance the security of your device.

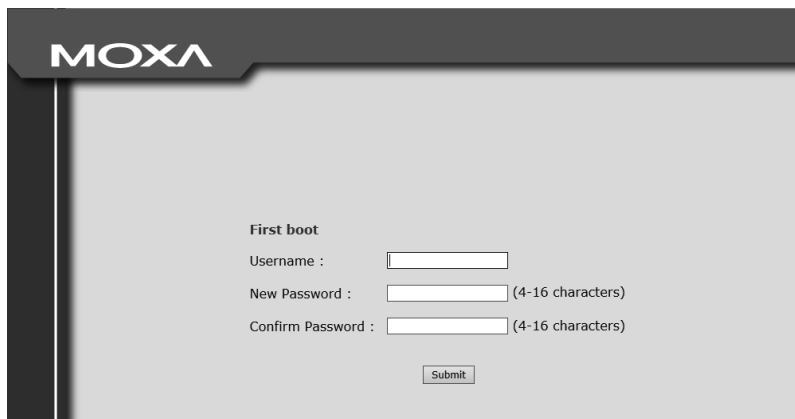

Moxa Tech Note The Security Hardening Guide for the NPort 6000 Series

3.1. TCP/UDP Ports and Recommended Services

Refer to the table below for all the ports, protocols, and services that are used to communicate between the NPort 6000 Series and other devices.

Service Name	Option	Default Setting	Type	Port Number	Description
Moxa Command (DSCI)	Enable/Disable	Enable	TCP	14900, 4900	For Moxa utility communication
			UDP	4800	
DNS_wins	Enable	Enable	UDP	53, 137, 949	Processing DNS and WINS (Client) data
SNMP agent	Enable/Disable	Enable	UDP	161	SNMP handling routine
RIPD_PORT	Enable/Disable	Disable	UDP	520, 521	Processing RIP routing data
HTTP server	Redirect to HTTPS/Disable	Disable	TCP	80	Web console
HTTPS server	Enable/Disable	Enable	TCP	443	Secured web console
SSH	Enable/Disable	Enable	TCP	22	SSH console
Telnet server	Enable/Disable	Disable	TCP	23	Telnet console
RADIUS	Enable/Disable	Disable	UDP	User-defined (1645 as default or 1812)	Authentication server
TACACS+	Enable/Disable	Disable	TCP	49	Authentication server
DHCP client	Enable/Disable	Disable	UDP	68	The DHCP client needs to acquire the system IP address from the server
SNTP	Enable/Disable	Disable	UDP	Random port	Synchronize time settings with a time server
Remote System Log	Enable/Disable	Disable	UDP	Random port	Send the event log to a remote log server

Operation Mode	Option	Default Setting	Type	Port Number	Description
Real COM Mode	Enable/Disable	Enable	TCP	950+ (Serial port No. -1) 966+ (Serial port No. -1)	
RFC2217 Mode	Enable/Disable	Disable	TCP	User-defined (default: 4000+Serial port No.)	
TCP Server Mode	Enable/Disable	Disable	TCP	User-defined (default: 4000+Serial Port No.) User-defined (default: 966+Serial Port No.)	
UDP Mode	Enable/Disable	Disable	UDP	User-defined (default: 4000+Serial Port No.)	

Moxa Tech Note The Security Hardening Guide for the NPort 6000 Series

Operation Mode	Option	Default Setting	Type	Port Number	Description
Pair Connection Slave Mode	Enable/Disable	Disable	TCP	User-defined (default: 4000+Serial Port No.)	
Ethernet Modem Mode	Enable/Disable	Disable	TCP	User-defined (default: 4000+Serial Port No.)	
Reverse Telnet Mode	Enable/Disable	Disable	TCP	User-defined (default: 4000+Serial Port No.)	
Reverse SSH Mode	Enable/Disable	Disable	TCP	User-defined (default: 4000+Serial Port No.)	
Printer RAW Mode	Enable/Disable	Disable	TCP	2048+(Group No. -1)	
Printer LPD Mode	Enable/Disable	Disable	TCP	515	
Disabled Mode	Enable/Disable	Disable	N/A	N/A	

For security reasons, you should consider disabling unused services. After initial setup, use services with stronger security for data communication. Refer to the table below for the suggested settings.

Service Name	Suggested Setting	Type	Port Number	Security Remark
Moxa Command (DSCI)	Disable	TCP	14900, 4900	Disable this service as it is not commonly used
		UDP	4800	
DNS_wins	Enable	UDP	53, 137, 949	A necessary service to get IP; cannot be disabled
SNMP	Disable	UDP	161	Suggest to manage the NPort via HTTPS console
RIPD_PORT	Disable	UDP	520, 521	Since the NPort is not a router or layer 3 switch, you may not need this service
HTTP Server	Disable	TCP	80	Disable HTTP to prevent plain text transmission
HTTPS Server	Enable	TCP	443	Encrypted data channel with trusted certificate for NPort configurations
SSH	Enable	TCP	22	If you prefer the console mode to configure the device, you can enable the SSH service. If you prefer the GUI, then disable it.
Telnet Server	Disable	TCP	23	Disable this service as it is not commonly used

Moxa Tech Note The Security Hardening Guide for the NPort 6000 Series

Service Name	Suggested Setting	Type	Port Number	Security Remark
RADIUS	Enable	UDP	User Define (1645 as default or 1812)	If you are using central account management feature (has a RADIUS server), you may enable this service.
TACACS+	Enable	TCP	49	If you are using the central account management feature (has a TACACS+ server), you may enable this service. Select either RADIUS or TACACS+ to be the central account management service, and disable the other one.
DHCP Client	Disable	UDP	67, 68	Assign an IP address manually for the device
SNTP Client	Disable	UDP	Random Port	Suggest to use the SNTP server for secure time synchronization
Remote System Log	Enable	UDP	Random port	Suggest using a system log server to store all the logs from all the devices in the network

For console services, we recommend the following:

HTTP	Disable
HTTPS	Enable
Telnet	Disable
Moxa Command	Disable

To enable or disable these services, log in to the HTTP/HTTPS console and select **Basic Settings → Console Settings**.

Console Settings

HTTP console

HTTPS console (support TLS v1.2)

TLS v1.0/v1.1 for HTTPS console

Telnet console

SSH console

Moxa Service

Redirect to HTTPS Disable

Enable Disable

Enable Disable

Enable Disable

Enable Disable

Enable Disable

Moxa Tech Note The Security Hardening Guide for the NPort 6000 Series

To disable the SNMP agent service, log in to the HTTPS console and select **System Management** → **SNMP Agent**, then select **Disable** for SNMP.

SNMP Agent Settings

Configuration

SNMP Enable Disable

Read community string (max: 31 characters)

Write community string (max: 31 characters)

Contact name

Location

SNMP agent version v1 v2 v3

Read only user name

Read only authentication mode

Read only password (8-31 characters)

Read only privacy mode

Read only privacy (8-31 characters)

Read/write user name

Read/write authentication mode

Read/write password (8-31 characters)

Read/write privacy mode

Read/write privacy (8-31 characters)

For the RADIUS server, log in to the HTTPS/SSH/Telnet console and select **System Management** → **Mics. Network Settings** → **Authentication Server**. Then, keep the IP setting empty as **Disable** for the RADIUS server.

Authentication Server

RADIUS

RADIUS server

RADIUS key

UDP port

RADIUS accounting Enable Disable

To disable the SNTP service, log in to the HTTP/HTTPS/SSH/Telnet console and select **Basic Settings**, and keep the **Time server** setting empty. This will disable the SNTP service.

Time Settings

Time zone

Local time (24-hour) / / : :

Time server

Moxa Tech Note The Security Hardening Guide for the NPort 6000 Series

For the remote system log server, it depends on your network architecture. We recommend your network administrator to have a Log Server to receive the log messages from the device. In this case, log in to the HTTP/HTTPS/SSH/Telnet console, select **Remote Log Server**, and input the IP address of the Log Server in the **SYSLOG server** field. If your network doesn't have one, keep it empty (disable **Remote System Log Server**).

Remote Log Server

Configuration

SYSLOG server	<input type="text"/>
SYSLOG facility	local use 0 ▾
SYSLOG severity	Emergency ▾

For the operation mode services, it depends on how you bring your serial device to the Ethernet network. For example, if your host PC uses a legacy software to open a COM port to communicate with the serial device, then the NPort will enable the Real COM mode for this application. If you don't want the NPort to provide such a service, log in to the HTTP/HTTPS/SSH/Telnet console, select **Serial Port Settings → Port # → Operation Modes**, and then select **Disable**.

Operation Modes

Port 1

Application	Disable ▾
Apply the above settings to	<input checked="" type="checkbox"/> P1 <input type="checkbox"/> P2
	<input type="checkbox"/> All ports

Note: For each instruction above, click the **Submit** button to save your changes, then restart the NPort device so the new settings will take effect.

Moxa Tech Note The Security Hardening Guide for the NPort 6000 Series

3.2. HTTPS and SSL Certificates

HTTPS is an encrypted communication channel. As TLS v1.1 or lower has severe vulnerabilities that can easily be hacked, the NPort 6000 Series uses TLS v1.2 for HTTPS to ensure data transmissions are secured. Make sure your browser has TLS v1.2 enabled.

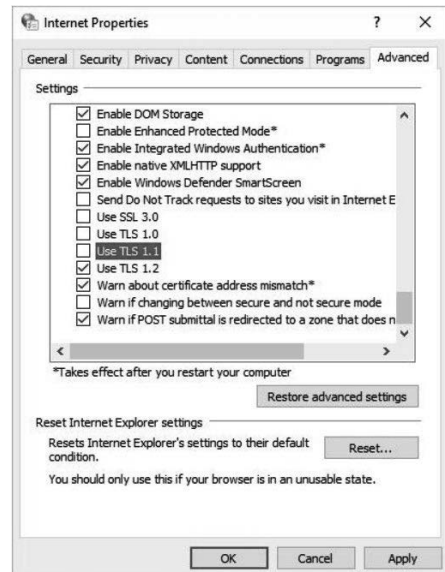

In order to use the HTTPS console without a certificate warning appearing, you need to import a trusted certificate issued by a third-party certificate authority.

Log in to the HTTP/HTTPS console and select **System Management** → **Certificate**.

You can generate an up-to-date valid certificate by importing a third-party trusted SSL certificate or generating the "NPort self-signed" certificate.

- Behavior of the SSL certificate on an NPort device
 - NPort devices can auto-generate a self-signed SSL certificate. It is recommended that you import SSL certificates that are either certified by a trusted third-party Certificate Authority (CA) or by an organization's CA.
 - The length of the NPort device's self-signed private keys is 1,024 bits, which should be compatible with most applications. Some applications may need a longer key, such as 2,048 bits, which would require importing a third-party certificate. Please note that longer keys will mean browsing the web console will be slower due to the increased complexity of encrypting and decrypting communicated data.

Moxa Tech Note **The Security Hardening Guide for the NPort 6000 Series**

- For the NPort self-signed certificate:

If a certificate has expired, you can regenerate the NPort self-signed certificate with the following steps.

- Step 1. **Delete** the current SSL certificate issued by the NPort device.
- Step 2. **Enable** the NTP server and set up the time zone and local time.
- Step 3. After restarting the device, the NPort self-signed certificate will be regenerated with a new expiration date.

- Importing a third-party trusted SSL certificate:

Importing the third-party trusted SSL certificate can improve security. To generate the SSL certificate through a third party, follow these steps:

- Step 1. Create a certification authority (Root CA), such as Microsoft AD Certificate Service (<https://mizitechinfo.wordpress.com/2014/07/19/step-by-step-installing-certificate-authority-on-windows-server-2012-r2/>)
- Step 2. Find a tool to issue a certificate signing request (CSR) file. You can get one from a third-party CA company such as DigiCert (<https://www.digicert.com/easy-csr/openssl.htm>).
- Step 3. Submit the CSR file to a public certification authority to get a signed certificate.
- Step 4. Import the certificate to the NPort device. Please note that NPort devices only accept certificates using a **“.pem”** format.

Note: The maximum supported key length for NPort devices is 2,048 bits.

Moxa Tech Note The Security Hardening Guide for the NPort 6000 Series

- Here are some well-known third-party CA (Certificate Authority) companies for your reference (https://en.wikipedia.org/wiki/Certificate_authority):
 - IdenTrust (<https://www.identrust.com/>)
 - DigiCert (<https://www.digicert.com/>)
 - Comodo Cybersecurity (<https://www.comodo.com/>)
 - GoDaddy (<https://www.godaddy.com/>)
 - Verisign (<https://www.verisign.com/>)

🔑 Certificate

Certificate Settings	
Issued to	10.144.8.226
Issued by	10.144.8.226
Valid	from 2000/3/4 to 2020/3/4
Select SSL certificate file	<input type="button" value="Choose File"/> No file chosen <input type="button" value="Import"/>
Delete SSL certificate file	<input type="button" value="Delete"/>

The screenshot shows the Moxa web interface for an NPort 6000 device. At the top, the Moxa logo and the slogan "Total Solution for Industrial Device Networking" are visible. Below this is a status bar displaying device information: Model (MGate MB3270), Name (MG MB3270_3348), IP (192.168.127.200), Serial No. (3348), MAC Address (00:90:E8:44:F0:E7), and Firmware (4.1.5 Build 19100215). A left-hand navigation menu lists various settings categories, with "Certificate" highlighted. The main content area displays a confirmation message: "Certificate Settings OK!". Below the message, it states "Your changes have been saved." and provides instructions to click "Restart" to reboot the server. At the bottom of the message area, there are three buttons: "Back", "Restart", and "Home".

3.3. Account Management

- The NPort 6000 Series provides two different user levels, administrator and user. With a Read Write account, you can access and modify all settings through the web console. With a user account, you can only view settings.
- The default administrator account is **admin**, and the default password is blank. To manage accounts, log in to the web console and select **Administration → Account Management → User Account**. To change the password of an existing account, click on the account name and select **Edit** in the top toolbar. Input the old password in the **Password** field and the new password in **Confirm Password** field to change the password.
- Through the administration account, admin, log in to NPort 6000 Series and perform the configuration settings. To change the default password (empty), log in to the HTTPS/SSH/Telnet console and select **System Management → Account Management → User Account**. When it comes to the **Password** part, input the old password and the new password twice (at least 4 characters) to change the password.

Change Password

Password	
Old password	<input type="text"/>
New password	<input type="text"/>
Confirm password	<input type="text"/>
User Management	
User Name	<input type="text"/>
User Old password	<input type="text"/>
User New password	<input type="text"/>
User Confirm password	<input type="text"/>
Action	<input checked="" type="radio"/> Change <input type="radio"/> Add <input type="radio"/> Delete

Moxa Tech Note The Security Hardening Guide for the NPort 6000 Series

- To add new general users, log in to the HTTPS/SSH/Telnet console and select **System Management → Maintenance → Change Password**. At the **User Management** part, input the username, old password, and the new password twice to **Add** a new user, **Change** the password, or **Delete** an old user.

User Account

Add Account

Active	<input checked="" type="checkbox"/>
Account Name	<input type="text"/>
Password	<input type="text"/>
Confirm Password	<input type="text"/>
Group	administrator ▼

Note: We suggest you manage your device with another “administrator level” account instead of using the default “admin” account, as it is commonly used by embedded systems. Once the new administrator level account has been created, it is suggested that the original “admin” account should be monitored for security reasons to prevent brute-force attacks.

Access Permission

Access Permission

+ Add ✎ Edit 🗑 Delete 💾 Save							
Group Name	Overview	Network Config	Serial Config	System Config	Administration	Log, Monitoring and Warning	Common Settings
administrator	Read Only	Read Write	Read Write	Read Write	Read Write	Read Write	Read Write
guest	Read Only	No Display	No Display	No Display	No Display	No Display	No Display
port_admin	Read Only	No Display	Read Write	Read Write	No Display	Read Write	Read Write

Moxa Tech Note The Security Hardening Guide for the NPort 6000 Series

- To improve security, the login password policy and account login failure lockout can be configured. To configure them, log in to the HTTP/HTTPS console and select **System Management → Misc. Settings → Login Password Policy**.

Account Password and Login Management

Account Password Policy

Password minimum length	<input type="text" value="16"/> (4 - 16)
Password complexity strength check	<input checked="" type="radio"/> Enable <input type="radio"/> Disable
At least one digit (0~9)	<input checked="" type="radio"/> Enable <input type="radio"/> Disable
Mixed upper and lower case letters (A~Z, a~z)	<input checked="" type="radio"/> Enable <input type="radio"/> Disable
At least one special character (~!@#\$\$%^&*-_!;,:.<>[]{}())	<input checked="" type="radio"/> Enable <input type="radio"/> Disable
Password lifetime	<input type="text" value="1"/> (0 - 180 day; 0 for Disable)

Account Login Failure Lockout

Account login failure lockout	<input checked="" type="radio"/> Enable <input type="radio"/> Disable
Retry failure threshold	<input type="text" value="5"/> (1 - 10 retry)
Lockout Time	<input type="text" value="5"/> (1 - 60 min)

You should adjust the password policy to require more complex passwords. For example, set the **Minimum length** to 16, enable all password complexity strength checks, and enable the **Password lifetime** options. Also, to avoid brute-force attack, it's suggested that you enable the **Account login failure lockout** feature.

- For some system security requirements, a warning message may need to be displayed to all users attempting to log in to the device. To add a login message, log in to the HTTPS console and select **System Management → Misc. Settings → Notification Message**, and enter a **Login Message** to use.

Notification Message

Notification Message

Notification Message	<input type="text" value="Welcome to Moxa NPort"/>	
Login Message	<input type="text" value="Please contact administration if you have forgotten the password."/>	21 characters/Maximum 240 characters
Login Authentication Failure Message	<input type="text" value=""/>	65 characters/Maximum 240 characters

3.4. Accessible IP List

- The NPort 6000 Series has a feature that can limit access to specific remote host IP addresses to prevent unauthorized access. If a host's IP address is in the accessible IP table, then the host will be allowed to access the NPort 6000 Series. To configure it, log in to the HTTPS console and select **System Management** → **Accessible IP List**.

Accessible IP List

- Activate the accessible IP list (Operation modes are NOT allowed for the IPs NOT on the list)
- Apply additional restrictions (All device services are NOT allowed for the IPs NOT on the list)

No.	Active	IP Address	Netmask/Prefix
1	<input type="checkbox"/>	<input type="text"/>	<input type="text"/>
2	<input type="checkbox"/>	<input type="text"/>	<input type="text"/>
3	<input type="checkbox"/>	<input type="text"/>	<input type="text"/>
4	<input type="checkbox"/>	<input type="text"/>	<input type="text"/>
5	<input type="checkbox"/>	<input type="text"/>	<input type="text"/>
6	<input type="checkbox"/>	<input type="text"/>	<input type="text"/>

- You may add a specific address or range of addresses by using a combination of an IP address and a netmask as follows:
 - To allow access to a specific IP address:** Enter the IP address in the corresponding field, then enter 255.255.255.255 for the netmask.
 - To allow access to hosts on a specific subnet:** For both the IP address and netmask, use 0 for the last digit (e.g., "192.168.1.0" and "255.255.255.0").
 - To allow access to all IP addresses:** Make sure that the **Enable** checkbox for the Accessible IP List is not checked.

Additional configuration examples are shown in the following table:

Desired IP Range	IP Address Field	Netmask Field
Any host	Disable	Enable
192.168.1.120	192.168.1.120	255.255.255.255
192.168.1.1 to 192.168.1.254	192.168.1.0	255.255.255.0
192.168.1.1 to 192.168.255.254	192.168.0.0	255.255.0.0
192.168.1.1 to 192.168.1.126	192.168.1.0	255.255.255.128



Warning

Ensure that the IP address of the PC you are using to access the web console is in the **Accessible IP List**.

Moxa Tech Note The Security Hardening Guide for the NPort 6000 Series

3.5. Logging and Auditing

- These are the events that will be recorded by the NPort 6000 Series:

Event Group	Summary
System	System cold start, System warm start
Network	DHCP/BOOTP gets IP/renew, NTP connect failed, IP conflict, Network link down
Configuration	Login failed, IP changed, Password changed, Firmware upgraded, Certificate imported, Configuration imported or exported, Configuration changed, Clear event logged
OpMode	Connect, Disconnect, Authentication Fail, Restart

- To configure this setting, log in to the HTTPS console and select **System Management → System Log Settings**. Then, enable the **Local Log** for recording on the NPort 6000 device and/or **Syslog** for keeping records on a server. You should enable system log settings to record all important system events to monitor device status and check for security issues.

System Log Settings

Event Group	Local Log	Remote Log	Summary
System	<input checked="" type="checkbox"/>	<input type="checkbox"/>	System Cold Start, System Warm Start
Network	<input checked="" type="checkbox"/>	<input type="checkbox"/>	DHCP/BOOTP/PPPoE Get IP/Renew, NTP, Mail Fail, NTP Connect Fail, IP Conflict, Network Link Down
Config	<input checked="" type="checkbox"/>	<input type="checkbox"/>	Login Fail, IP Changed, Password Changed, Config Changed, Firmware Upgrade, SSL Certificate Import, Config Import, Config Export
OpMode	<input checked="" type="checkbox"/>	<input type="checkbox"/>	Connect, Disconnect, Authentication Fail, Restart

- To view events in the system log, log in to the HTTP/HTTPS console and select **System Monitoring → System Log**.

System Log

System Log
2014/02/07 12:36:25 [System] System Warm Start
2014/02/07 12:36:28 [Network] DHCP/BOOTP/PPPoE Get IP/Renew
2014/02/07 12:36:36 [Network] Get IP Fail (IPv6)
2014/02/10 04:40:32 [System] System Cold Start
2014/02/10 04:40:43 [Network] Get IP Fail (IPv6)
2014/02/10 05:18:18 [Network] DHCP/BOOTP/PPPoE Get IP/Renew
2014/02/20 09:10:33 [System] System Cold Start
2014/02/20 09:10:44 [Network] Get IP Fail (IPv6)
2014/02/24 04:50:09 [System] System Cold Start
2014/02/24 04:50:20 [Network] Get IP Fail (IPv6)
2014/02/24 13:54:11 [Network] DHCP/BOOTP/PPPoE Get IP/Renew
2014/03/10 07:18:33 [System] System Cold Start
2014/03/10 07:18:49 [Network] Get IP Fail (IPv6)
2014/03/10 09:54:20 [Config] Config Changed
2014/03/10 09:54:35 [System] System Warm Start
2014/03/10 09:54:46 [Network] Get IP Fail (IPv6)
2014/03/10 09:56:15 [Config] Config Changed
2014/03/10 09:56:18 [Config] IP Changed
2014/03/10 09:56:30 [System] System Warm Start

4. Patching/Upgrades

4.1. Patch Management

With regards to patch management, Moxa releases version enhancements annually with detailed release notes.

4.2. Firmware Upgrades

The process for upgrading firmware is as follows:

- Download the latest firmware for your MGate device from the Moxa website:
 - Firmware for the NPort 6100/6200 Series:
<https://www.moxa.com/en/products/industrial-edge-connectivity/serial-device-servers/terminal-servers/nport-6100-6200-series#resources>
 - Firmware for the NPort 6400/6600 Series:
<https://www.moxa.com/en/products/industrial-edge-connectivity/serial-device-servers/terminal-servers/nport-6400-6600-series#resources>
- Log in to the HTTPS console and select **System Management** → **Maintenance** → **Firmware Upgrade**. Click the **Choose File** button to select the proper firmware and click **Submit** to upgrade the firmware.

⚙️Firmware Upgrade

!!! Warning !!!

Note: Firmware upgrade will discard your un-saved configuration changes and restart the system!

Select firmware file

Choose File No file chosen

Submit

Moxa Tech Note The Security Hardening Guide for the NPort 6000 Series

- If you want to upgrade the firmware for multiple units, download the Device Search Utility (DSU) or MXconfig for a GUI interface, or the Moxa CLI Configuration Tool for a CLI interface.

FILTER All Driver Firmware Library Software Package Utility

NAME	TYPE	VERSION	OPERATING SYSTEM	RELEASE DATE
Device Search Utility <small>1.1 MB</small>	Utility	v2.3	- Windows 10 - Windows 2000 - Windows 7 Show More	Sep 01, 2019 Release notes
Moxa CLI Configuration Tool for Linux <small>8.1 MB</small>	Utility	v1.1	- Linux Kernel 2.6.x - Linux Kernel 3.x - Linux Kernel 4.x	Jan 17, 2019 Release notes
Moxa CLI Configuration Tool for Windows <small>1.4 MB</small>	Utility	v1.1	- Windows 10 - Windows 7 - Windows 8 Show More	Jan 16, 2019 Release notes
PComm Lite - Serial Communication Tool for Windows <small>1.6 MB</small>	Utility	v1.6	- Windows 2000 - Windows 7 - Windows Server 2003 Show More	May 13, 2012 Release notes
MXconfig <small>118.1 MB</small>	Software Package	v2.6	- Windows 10 - Windows 7 - Windows 8 Show More	May 29, 2020 Release notes

- If you need instructions on using the Moxa CLI Configuration Tool, download the manual.
 - Manual for the NPort 6100/6200 Series:
<https://www.moxa.com/en/products/industrial-edge-connectivity/serial-device-servers/terminal-servers/nport-6100-6200-series#resources>
 - Manual for the NPort 6400/6600 Series:
<https://www.moxa.com/en/products/industrial-edge-connectivity/serial-device-servers/terminal-servers/nport-6400-6600-series#resources>

5. Security Information and Vulnerability Feedback

As the adoption of the Industrial IoT (IIoT) continues to grow rapidly, security has become one of the top priorities. The Moxa Cyber Security Response Team (CSRT) is taking a proactive approach to protect our products from security vulnerabilities and help our customers better manage security risks.

You can find the latest Moxa security information here:

<https://www.moxa.com/en/support/product-support/security-advisory>